

PG03-030-X

160mm gas lifter, 30N - two mounts

Reference: PG03-030-X

EAN Code:

Material: Steel

Material color: Silver

Length: 160mm

Working force: 30N



[More info](#)

BOUGHT PRODUCT INCLUDES:

1. board fixture
2. **PG03-030-X** gas lifter
3. side board fixture
4. screws needed for installation

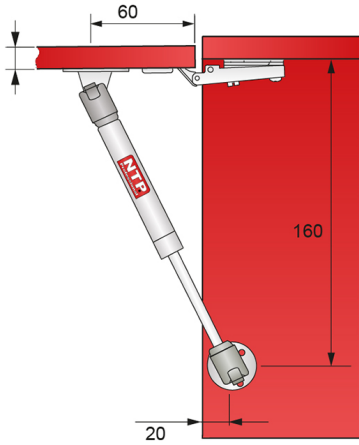
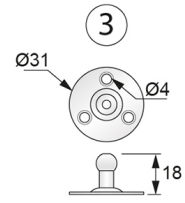
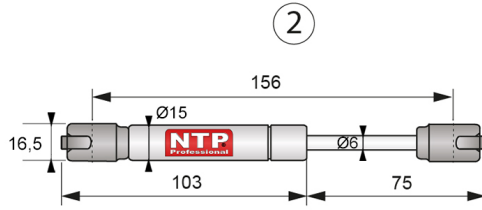
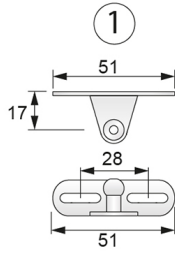

Waga frontu w zależności od siły podnośnika i wysokości frontu
Weight of doors depending on door height and lifting forces

Siła podnośnika (N) damping force (N)	Wysokość frontu(mm / door height (mm))			
	300	400	500	600
30	0.61	0.46	0.37	0.31

